

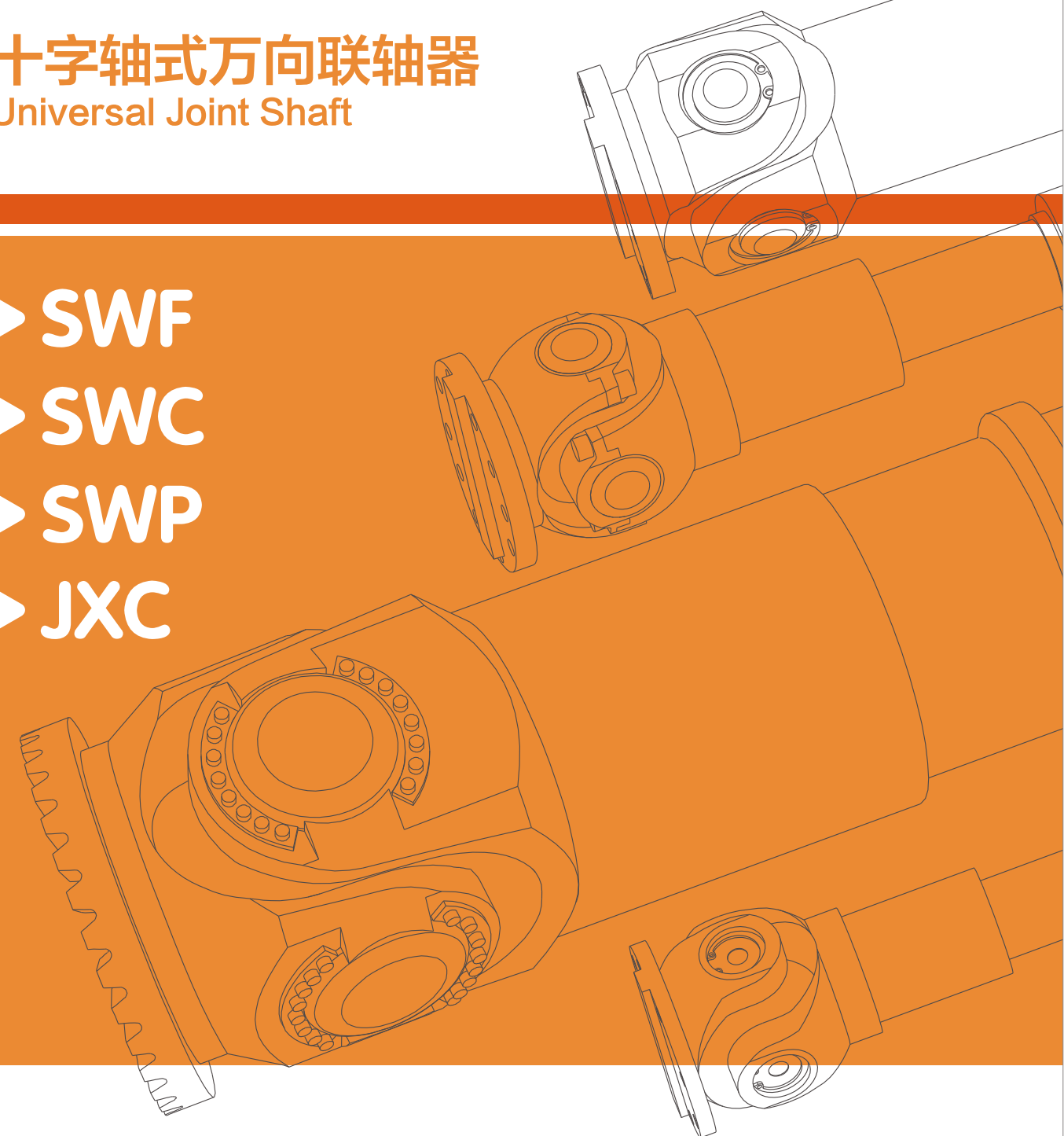

十字轴式万向联轴器 Universal Joint Shaft

- ▶ SWF
- ▶ SWC
- ▶ SWP
- ▶ JXC



Originally constructed in March,2012

*Our products are advanced regularly, the final products maybe a little differ with this catalogue, any questions please contact us.

订货说明

型号标注说明

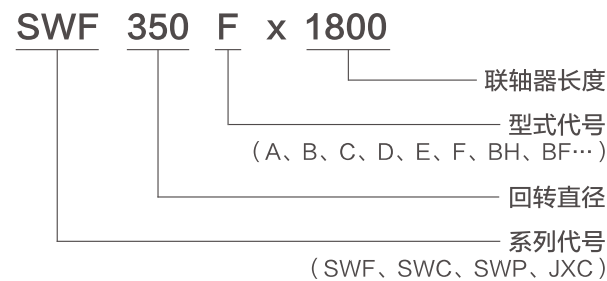

订货时请用户先提供十字轴式万向联轴器工作转矩、最大瞬时转矩、冲击系数、工况条件、是否带负载正反转、使用转速、使用轴夹角、总长度、伸缩量、两端配合尺寸及其它特殊要求，以便我方协助用户选型。

与十字轴式万向联轴器法兰连接的轴接套和连接法兰所需的高强度螺栓组一般由用户自备，但也可由需方提供轴接套图纸，由我方一并供货。

选用说明

※ 起重机用万向联轴器的选用见我公司2012年3月版《专用于起重机》样本。

1、强度验算：

$$T_c = K_1 \cdot K_2 \cdot T \leq T_m$$

或： $T_c \leq T_p$ 在脉动交变载荷时

或： $T_c \leq T_f$ 在对称交变载荷时

T_c - 计算转矩 (kN·m)

T - 理论转矩, $T = 9.55 \frac{N}{n}$ (kN·m)

N - 电机额定功率 (kW)

n - 联轴器转速 (r/min)

T_m 、 T_p 、 T_f - 见性能表

K_1 - 冲击系数，见下表

K_2 - 电机最大过载系数，取2.5或按实际过载系数。

负荷性质	K_1
轻、中冲击负荷	1.0-1.2
重冲击负荷	> 1.2-1.5
特重冲击负荷	> 1.5

安装使用维护说明

为满足正常使用和装卸方便，推荐与联轴器相连法兰凸出口采用f8配合，其端面键槽采用H8配合。安装时各法兰面须清理干净，连接法兰的高强度螺栓须按规定预紧并防松。如将花键轴重装入花键套时，须注意两端叉头上的轴承孔中心线须在同一平面内，否则将降低联轴器使用性能。使用中如发现异常声音或跳动，应及时由专业人员检查。

十字轴式万向联轴器在出厂时各处已注7029A聚氨酯润滑脂，用户可用相应牌号清洁的润滑脂按情况注油（一般1-3个月），每次注油后须拧好油堵。

同步所需条件

同时满足下列三条件时才能同步，即输入轴、输出轴、与联轴器轴线形成的夹角相等；入轴、出轴和联轴器三轴线在同一平面内；中间轴两端叉头轴承中心线在同一平面内。

2、轴承寿命计算：

$$L_h = \frac{1.5 \times 10^7}{n \times \alpha} \left(\frac{A}{T \times K_d} \right)^{10/3}$$

L_h - 净工作寿命 (h)

α - 轴夹角 (度)， $\alpha < 3^\circ$ 时取3°

A - 见性能表

K_d - 工况系数，见下表

工况	K_d
满载率低，工作较平稳，工作条件较好	1.1-1.3
较易过载，冲击较大，工作条件较差	> 1.3-1.5
经常过载，冲击极大，工作条件很差	> 1.5

3、转动灵活性验算：

对 $D \leq 500$ 的联轴器以下式进行验算：

$$n \times \alpha < 18000$$

Ordering Instructions

Model Example:

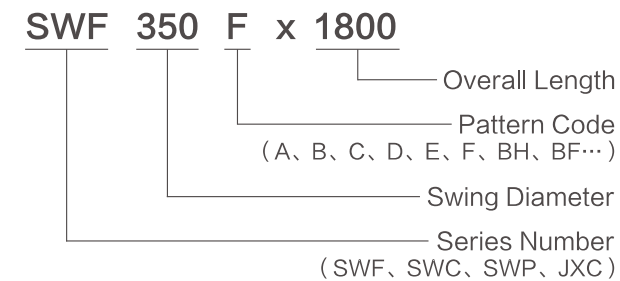

When ordering, please provide accordingly rated torque, the maximum instantaneous torque, shaft angle, rotating speed, impact conditions, with or without load rotating, overall length and fitting dimension for both ends and other specific requirements in order to assist the user to make a proper choice.

The high strength bolts for connecting flanges can be prepared by users themselves or supplied by us (please supply the drawing of your shaft sleeve).

Selection description

*Crane universal joint shaft please check another sample for crane published in March of 2012.

1.Strength checking:

$$T_c = K_1 \cdot K_2 \cdot T \leq T_m$$

Or $T_c \leq T_p$ In pulse amplitude load

Or $T_c \leq T_f$ In symmetrical alternating load

T_c - Computed Torque (kN·m)

T - Rated torque, $T = 9.55 \frac{N}{n}$ (kN·m)

N - Motor rated power (kW)

n - Speed (r/min)

T_m 、 T_p 、 T_f - Please check the form

K_1 - Impact coefficient, please check the form

K_2 - Maximum overload coefficient, please Check 2.5 or according to the real coefficient.

Load class	K_1
Light and medium impact load	1.0-1.2
Heavy impact load	> 1.2-1.5
Very heavy impact load	> 1.5

Installing and Maintenance Instructions

In order to use it easily, we recommend cooperation f8 for outshot of flange and cooperation H8 for keyway of end surface key. Keep the flange surface clean when installing and check the connecting bolts regularly, and tighten them with a stipulated pre-tightening force. If there is abnormal sound or move up and down, please examine it in time by professional.

The universal joint shaft is lubricated with urea-based grease 7029A after production. Users can use other grease for replacement. (Please lubricate it each time in one or three months, then twist greasy blockage)

Synchronization Conditions

Only when the following three conditions are all satisfied that it can be synchronized, that is, the included angles of input axis and output axis, and axis of universal joint shaft, should be equal; input axis, output axis and axis of universal joint shaft should be in the same plane; bearing's centerlines of double end fork head of intermediate axis should be in the same plane.

2.Bearing life calculation:

$$L_h = \frac{1.5 \times 10^7}{n \times \alpha} \left(\frac{A}{T \times K_d} \right)^{10/3}$$

L_h - Working life (h)

α - Shaft axis (degree), when $\alpha < 3^\circ$, make it as 3°

A - Performance Form

K_d - Working condition, please check the form

working condition	K_d
Seldom fully loaded, work stably, good condition	1.1-1.3
Easily overload, big impact, bad condition	> 1.3-1.5
Overload often, bigger impact, very bad condition	> 1.5

3. Turn flexibility:

When $D \leq 500$:
 $n \times \alpha < 18000$

SWF系列 SWF Series

F型：可伸缩基本型
F Style : Basic flexible type

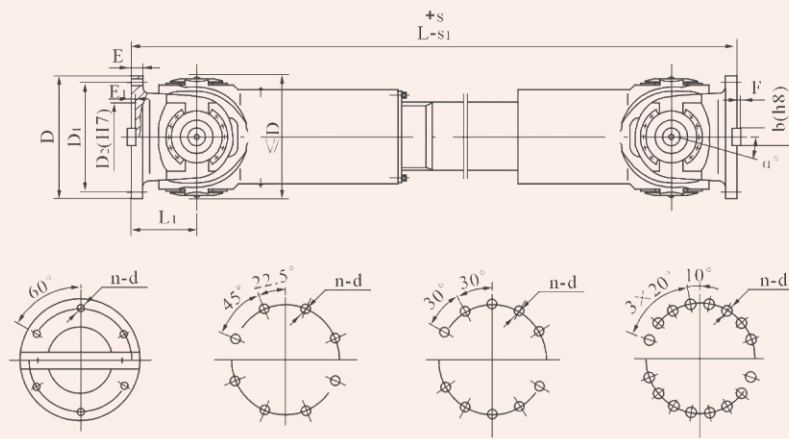

A型：可伸缩长型
A Style :Flexible long type

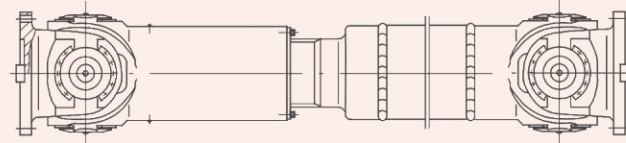

B型：可伸缩短型
B Style: Flexible short type

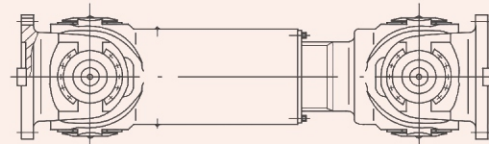

C型：无伸缩短型
C Style :No-flexible short type

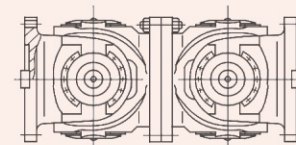

D型：无伸缩长型
D Style: No-flexible long type

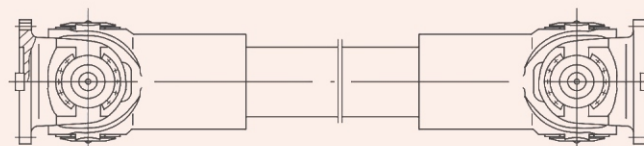

E型：大伸缩量型
E Style: Long flexible type

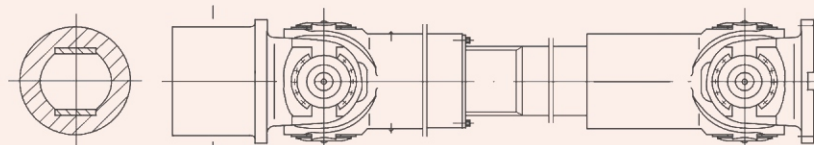

主要性能及尺寸 The main performance and sizes

型号 Style	Tm	Tp	Tf	A	α	L1	D	D1	D2	n-d	b	F	E	E1	S	S1
	kN · m															
SWF225	51	42	29	10.64	15°	130	225	196	135	8- Φ 17.5	32	9	20	5	40	25
SWF250	59	51	34	13.8		140	250	218	150	8- Φ 20	40	12.5	25	6	40	30
SWF285	96	82	54	19		160	285	245	170	8- Φ 22	40	15	27	7	50	35
SWF315	139	117	78	26		180	315	280	185	10- Φ 24	40	15	32	8	55	35
SWF350	220	188	125	36.6		195	350	310	210	10- Φ 24	50	16	35	8	60	40
SWF390	285	242	162	49.6		215	390	345	235	10- Φ 26	70	18	40	8	60	40
SWF435	470	390	272	72.3		245	435	385	255	16- Φ 29.5	80	20	42	10	75	45
SWF490	575	485	320	95.4		270	490	435	275	16- Φ 33	90	22.5	47	12	85	55
SWF550	827	703	408	137.5		305	550	492	320	16- Φ 33	100	25	50	12	95	60
SWF620	1183	1000	582	193.5		340	620	565	320	16- Φ 33	100	25	55	13	105	65
SWF680	1900	1600	1000	260	335	680	615	400	16- Φ 39	120	30	65	15	105	65	
SWF780	2950	2500	1550	390	375	780	715	400	16- Φ 39	120	30	65	15	120	85	
SWF840	3500	2900	1840	480	405	840	765	430	16- Φ 45	150	38	80	18	120	85	
SWF920	4600	3900	2400	630	440	920	830	430	16- Φ 51	150	38	80	18	150	100	
SWF1000	5700	4800	3000	800	485	1000	900	450	16- Φ 55	180	45	100	22	150	100	
SWF1100	8000	6800	4200	1050	530	1100	995	470	16- Φ 59	180	45	100	22	180	120	
SWF1200	11000	9300	5800	1360	590	1200	1080	500	16- Φ 67	200	50	120	25	180	120	

注：1.Tm、Tp、Tf——分别为最大允许静转矩，允许脉动疲劳转矩及允许对称疲劳转矩。 2.A——反映轴承容量的值。
Note:1.Tm,Tp,Tf - Represent the maximum allowed static torque, allowed pulse fatigue torque and allowed symmetric fatigue torque.
2.A-Represent the value of bearing capacity.

长度、重量及转动惯量 Length, weight and moment of inertia

	SWF	225	250	285	315	350	390	435	490	550	620
F	Lmin mm	980	1070	1220	1380	1510	1690	1880	2080	2385	2830
	Go kg	187	251	367	517	677	1010	1477	2009	2875	4296
	G100 kg	7.78	9.69	12.15	15.87	20.09	24.8	30	35.7	48.6	63.49
	Io kgm ²	0.71	1.2	2	3.4	5.8	11.8	21.1	26.46	47.36	154
	I100 kgm ²	0.017	0.019	0.027	0.037	0.1	0.12	0.15	0.17	0.25	0.81
A	Lmin mm	998	1095	1235	1400	1545	1705	1910	2100	2405	2710
	Go kg	175	233	342	479	623	936	1378	1880	2670	3910
	G100 kg	7.65	9.08	11.1	14.15	18.7	25.7	35.96	36.8	48.5	59.5
	Io kgm ²	0.75	1.2	2.6	4.6	8.0	13.2	25.5	44.3	73.5	145.2
	I100 kgm ²	0.026	0.037	0.06	0.11	0.18	0.26	0.41	0.68	1.11	1.72
B	Lmin mm	700	780	890	1000	1120	1240	1400	1580	1810	2050
	Go kg	143	197	289	405	568	755	1088	1513	2179	3143
	Io kgm ²	0.71	1.3	2.4	4.4	7.5	12.1	23.7	44.5	69.5	142.6
C	Lmin mm	520	560	640	720	780	860	980	1080	1220	1360
	Go kg	110	146	216	297	397	544	788	1077	1532	2171
	Io kgm ²	0.63	1.16	2.35	3.6	5.73	10.8	21.7	35.5	61.8	128.3
D	Lmin mm	600	660	760	860	920	1020	1160	1280	1420	1600
	Go kg	115	152	228	315	419	579	843	1153	1620	2299
	G100 kg	8.4	10.6	13	17.1	21.7	27.9	35.8	43.5	55.9	69.8
	Io kgm ²	0.64	1.1	2.3	4.1	6.42	12.6	22.3	38.0	61.8	143
	I100 kgm ²	0.03	0.04	0.08	0.12	0.20	0.28	0.44	0.74	1.12	1.78

注：1.E型的参数视扁套尺寸而定。SWF680及以上大规格的参数用户需要时提供。 2.Lmin——公称最短长度。
3.Go、Io——分别为最短长度Lmin时的自重及转动惯量。 4.G100、I100——分别为长度增加100mm时重量、转动惯量的增量。
Note: 1.The parameter of E Style is according to dimension of sleeve . Parameters for above SWF 680 should be supplied from users.
2.Lmin - Nominal shortest length. 3.Go,Io - Represent weight and moment of inertia during the shortest length.
4.G100,I100 - Represent incremental weight and moment of inertia when the length is added by 100mm.

SWC系列 SWC Series

BH型：标准伸缩焊接型
BH Style: Standard flexible welded type

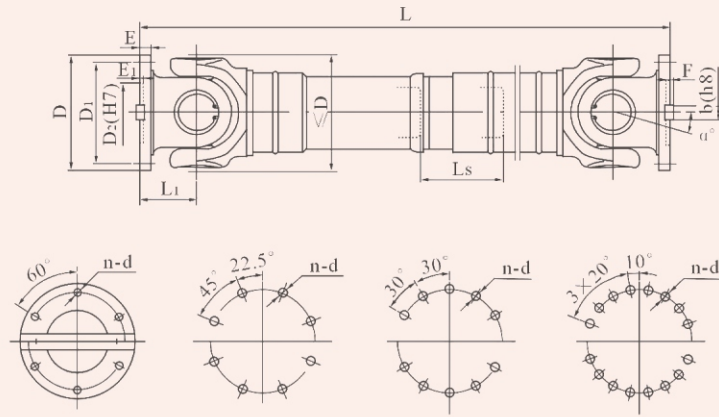

BF型：标准伸缩法兰型
BF Style: Standard flexible flange type

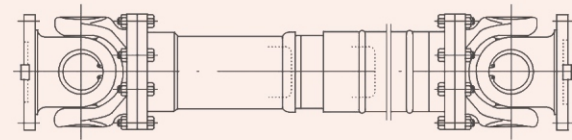

DH型：短伸缩焊接型
DH Style: Short flexible welded type

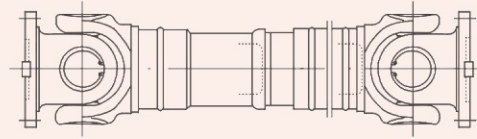

CH型：长伸缩焊接型
CH Style: Long flexible welded type

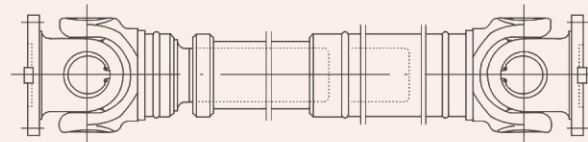

WH型：无伸缩焊接型
WH Style :No-flexible welded type

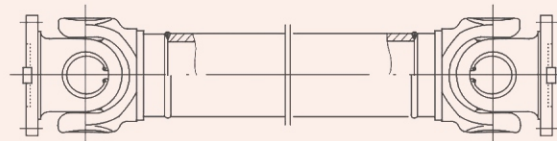

WF型：无伸缩法兰型
WF Style :No-flexible flange type

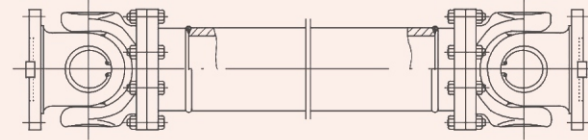

WD型：无伸缩短型
WD Style :No-flexible short type

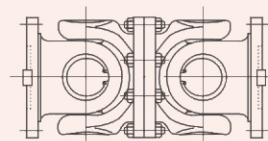

主要性能及尺寸 The main performance and sizes

型号 Style	Tm	Tp	Tf	A	α	L1	D	D1	D2	n-d	b	F	E	E1
	kN · m													
SWC100	1.3	1.1	0.69	0.63	25°	55	100	84	57	6-Φ9	-	-	7	2.5
SWC120	2.6	2.2	1.4	1.16		65	120	102	75	8-Φ11	-	-	8	2.5
SWC150	5.3	4.4	2.8	2.18		80	150	130	90	8-Φ13	-	-	10	3
SWC180	13.2	11.1	6.9	4.87		110	180	155	105	8-Φ17.5	-	-	17	5
SWC200	33	24.3	16.8	6.7		115	200	170	120	8-Φ17.5	28	8	17	5
SWC225	44.8	38	23.6	8.35	15°	120	225	196	135	8-Φ17.5	32	9	20	5
SWC250	53.8	45.6	28.4	11.1		140	250	218	150	8-Φ20	40	12.5	25	6
SWC285	85.6	72.6	45.2	16.8		160	285	245	170	8-Φ22	40	15	27	7
SWC315	109	92	57	22.3		180	315	280	185	10-Φ24	40	15	32	8
SWC350	149	127	79	32.1		194	350	310	210	10-Φ24	50	16	35	8
SWC390	263	224	139	45.3		215	390	345	235	10-Φ26	70	18	40	8
SWC440	388	329	205	63.5		260	440	390	255	16-Φ29.5	80	20	42	10
SWC490	498	422	263	83.8		270	490	435	275	16-Φ33	90	22.5	47	12
SWC550	731	620	386	121		305	550	492	320	16-Φ33	100	22.5	50	12
SWC620	1024	868	541	170		340	620	555	380	16-Φ33	100	25	55	12

注：1.Tm、Tp、Tf——分别为最大允许静转矩，允许脉动疲劳转矩及允许对称疲劳转矩。 2.A——反映轴承容量的值。
Note:1.Tm, Tp, Tf - Represent the maximum allowed static torque, allowed pulse fatigue torque and allowed symmetric fatigue torque. 2.A-Represent the value of bearing capacity.

长度、重量、转动惯量及伸缩量 Length, weight, moment of inertia and flexible length

SWC		100	120	150	180	200	225	250	285	315	350	390	440	490	550	620
BH	Lmin mm	405	485	590	810	840	920	1000	1140	1280	1410	1560	1830	2010	2300	-
	Go kg	9.2	13.4	29	74	108	154	205	301	420	551	816	1253	1694	2418	-
	Io kgm ²	0.0044	0.0109	0.0423	0.175	0.35	0.538	0.966	2.011	3.605	7.053	12.164	21.42	32.86	68.92	-
	Ls mm	55	80	80	100	110	140	140	140	140	150	170	190	190	240	-
BF	Lmin mm	-	-	-	810	840	920	1000	1140	1280	1410	1560	1830	2010	2300	2500
	Go kg	-	-	-	88	120	170	221	333	466	601	895	1353	1874	2605	3463
	Io kgm ²	-	-	-	0.267	0.55	0.788	1.445	2.873	5.094	9.195	16.62	28.24	46.33	86.98	147.5
	Ls mm	-	-	-	100	110	140	140	140	140	150	170	190	190	240	240
DH	Lmin mm	-	-	-	600	640	670	750	880	980	1090	1200	-	-	-	-
	Go kg	-	-	-	62	84	124	169	251	352	494	657	-	-	-	-
	Io kgm ²	-	-	-	0.16	0.29	0.397	0.885	1.801	3.163	5.824	10.763	-	-	-	-
	Ls mm	-	-	-	40	60	70	70	80	90	90	90	-	-	-	-
CH	Lmin mm	-	-	-	925	970	1020	1215	1475	1600	1715	1845	2110	2220	2585	-
	Go kg	-	-	-	79	114	164	224	339	474	642	898	1390	1790	2620	-
	Io kgm ²	-	-	-	0.181	0.37	0.561	1.016	2.156	3.812	7.663	12.73	22.54	33.97	72.79	-
	Ls mm	-	-	-	200	200	220	300	400	400	400	400	400	400	500	-
WH	Lmin mm	243	307	350	480	500	560	620	720	805	875	955	1155	1205	1355	-
	Go kg	6.1	9.8	21.3	52.7	67.2	98	133	198	274	364	504	798	1088	1473	-
	Io kgm ²	0.0039	0.0096	0.0371	0.15	0.246	0.365	0.847	1.756	2.893	5.013	8.406	15.79	26.54	48.32	-
WF	Lmin mm	-	-	-	560	585	640	710	800	900	980	1100	1220	1360	1510	1690
	Go kg	-	-	-	65.8	84.2	122	159	238	321	381	644	894	1364	1598	2396
	Io kgm ²	-	-	-	0.248	0.316	0.636	1.352	2.664	4.469	7.388	13.184	23.25	40.75	68.48	127.53
WD	Lmin mm	-	-	-	440	460	520	560	640	720	780	860	980	1080	1220	1360
	Go kg	-	-	-	53	68.4	102	136	202	278	371	509	783	1042	1483	2101
	Io kgm ²	-	-	-	0.145	0.261	0.355	0.831	1.715	2.82	4.791	8.229	15.32	25.74	46.78	83.76
G100 kg	0.9	1.42	2.38	4.17	5.25	6.45	7.78	9.69	12.15	15.87	24.8	30	30	48.6	48.6	
I100 kgm ²	0.00019	0.00044	0.00157	0.007	0.013	0.0234	0.0277	0.051	0.0795	0.2219	0.2219	0.4744	0.4744	1.357	1.357	

注：1.Lmin——缩短后的最小长度。 2.Go、Io——分别为最短长度Lmin时的自重及转动惯量。
3.G100、I100——分别为长度增加100mm时重量、转动惯量的增量。
Note: 1.Lmin - The shortest length after flexed. 2.Go, Io - Represent weight and moment of inertia during the shortest length. 3.G100, I100 - Represent incremental weight and moment of inertia when the length is added by 100mm.

SWP系列 SWP Series

F型：可伸缩基本型
F Style : Basic flexible type

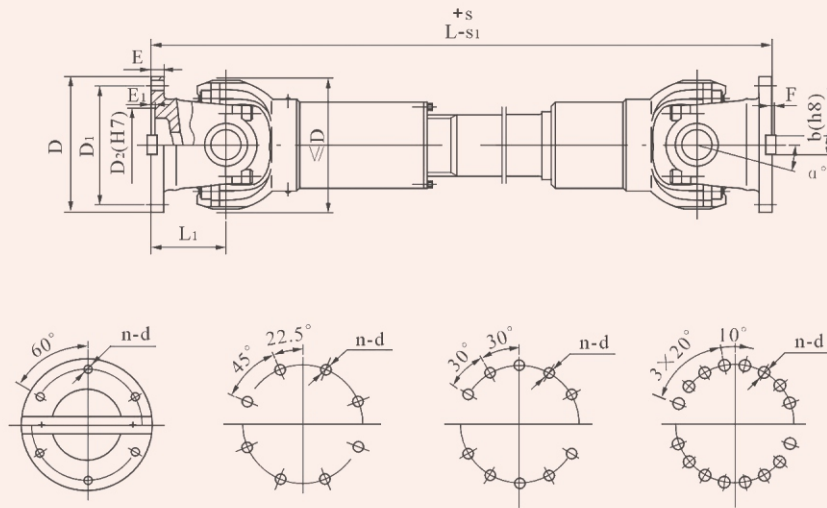

A型：可伸缩长型
A Style: Flexible long type

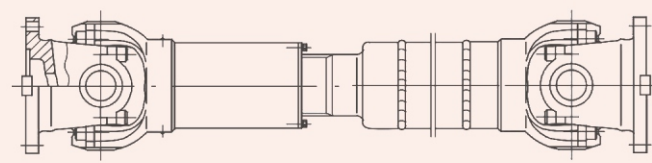

B型：可伸缩短型
B Style : Flexible short type

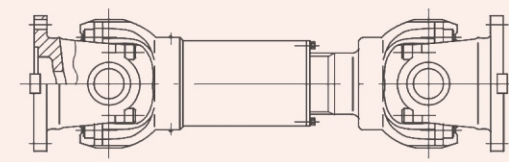

C型：无伸缩短型
C Style ; No-flexible short type

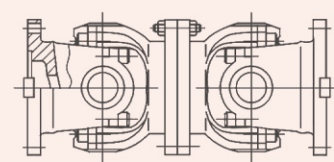

D型：无伸缩长型
D Style : No-flexible long type

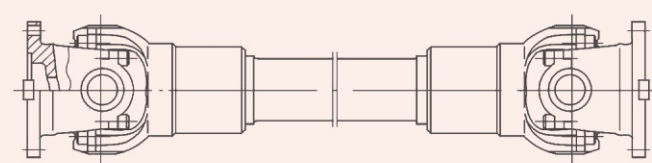

主要性能及尺寸 The main performance and sizes

型号 Style	Tm	Tp	Tf	A	α	L1	D	D1	D2	n-d	b	F	E	E1	S	S1
	kN · m															
SWP160	10.4	8.8	5.8	2.89	10°	85	160	140	95	6- Φ 13	20	6	15	4	25	15
SWP180	13.9	11.8	7.7	4.05		95	180	155	105	6- Φ 15.5	24	7	15	4	30	20
SWP200	19.1	16.3	10.7	5.53		110	200	175	125	8- Φ 15.5	28	8	17	5	35	20
SWP225	28.6	24.3	15.9	7.86		130	225	196	135	8- Φ 17.5	32	9	20	5	40	25
SWP250	38	32.2	21.1	11.1		135	250	218	150	8- Φ 20	40	12.5	25	5	40	30
SWP285	63.9	54.3	35.4	16.0		150	285	245	170	8- Φ 22	40	15	27	7	50	35
SWP315	98	83	54	22.3		170	315	280	185	10- Φ 24	40	15	32	7	55	35
SWP350	131	111	72	29.3		185	350	310	210	10- Φ 24	50	16	35	8	60	40
SWP390	166	141	92	39.2		205	390	345	235	10- Φ 26	70	18	40	8	60	40
SWP435	313	266	173	54.3		235	435	385	255	16- Φ 29.5	80	20	42	10	75	45
SWP480	434	366	239	73.8		265	480	425	275	16- Φ 33	90	22.5	47	12	85	55
SWP550	658	559	364	99.4		290	550	492	320	16- Φ 33	100	22.5	50	12	95	60

注：1.Tm、Tp、Tf——分别为最大允许静转矩，允许脉动疲劳转矩及允许对称疲劳转矩。2.A——反映轴承容量的值。
Note: 1.Tm, Tp, Tf - Represent the maximum allowed static torque, allowed pulse fatigue torque and allowed symmetric fatigue torque. 2.A-Represent the value of bearing capacity.

长度、重量及转动惯量 Length, weight and moment of inertia

SWP		160	180	200	225	250	285	315	350	390	435	480	550
F	Lmin mm	610	700	780	928	958	1103	1240	1400	1480	1740	1940	2125
	Go kg	62	78.1	108	159	213	308	436	547	794	1275	1691	2205
	G100 kg	3.2	3.8	4.8	6.4	6.4	9.6	12.1	15.8	15.8	24.7	27.1	32.6
	lo kgm ²	0.13	0.22	0.31	0.61	1.08	1.83	2.95	5.18	9.41	17.52	28.69	47.36
	I100 kgm ²	0.0029	0.0046	0.0076	0.0159	0.0159	0.0225	0.0310	0.0805	0.0805	0.1228	0.1806	0.2543
A	Lmin mm	660	752	823	933	978	1133	1250	1380	1495	1710	1910	2135
	Go kg	59	75.9	102.3	143	206	293	407	516	754	1159	1611	2126
	G100 kg	2.3	2.3	3.1	4.6	5.4	7.6	9	12.7	14.3	18.8	22.5	27.3
	lo kgm ²	0.13	0.22	0.37	0.63	1.02	2.17	3.86	6.66	11.53	21.81	38.04	61.28
	I100 kgm ²	0.0057	0.0069	0.0096	0.022	0.031	0.0502	0.0886	0.1526	0.22	0.34	0.5647	0.9279
	Lmin mm	455	510	580	670	710	790	915	1000	1070	1230	1380	1510
	Go kg	50	65	87	129	183	254	356	449	656	1025	1413	1830
	lo kgm ²	0.14	0.23	0.36	0.61	0.98	2.12	3.80	6.60	10.5	22.4	38.2	61
C	Lmin mm	340	380	440	520	540	600	680	740	820	940	1060	1160
	Go kg	39.6	52.8	74.8	105	167	218	293	362	576	855	1126	1595
	lo kgm ²	0.11	0.17	0.29	0.51	0.93	1.88	2.88	4.59	8.64	17.41	28.25	49.49
D	Lmin mm	430	474	544	636	690	760	860	940	1060	1180	1360	1460
	Go kg	44	59.4	84.7	124	196	251	343	428	668	1026	1095	1936
	G100 kg	2.6	2.7	3.4	5.4	6	8.5	9.8	13.6	15.3	19.9	23.7	29.1
	lo kgm ²	0.09	0.16	0.28	0.53	0.91	1.91	3.39	5.35	10.54	18.56	31.69	51.46
	I100 kgm ²	0.0071	0.0085	0.0114	0.025	0.035	0.0655	0.098	0.165	0.2356	0.365	0.614	0.934

注：1.Lmin——公称最短长度。 2.Go、lo——分别为最短长度Lmin时的自重及转动惯量。
3.G100、I100——分别为长度增加100mm时重量、转动惯量的增量。
Note: 1.Lmin - Nominal shortest length. 2.Go, lo - Represent weight and moment of inertia during the shortest length. 3.G100, I100 - Represent incremental weight and moment of inertia when the length is added by 100mm.

JXC系列 JXC Series

F型：可伸缩基本型
F Style ; Basic flexible type

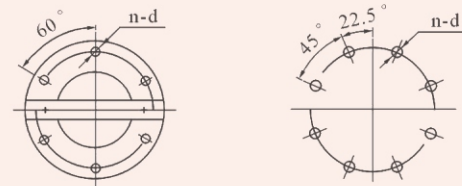
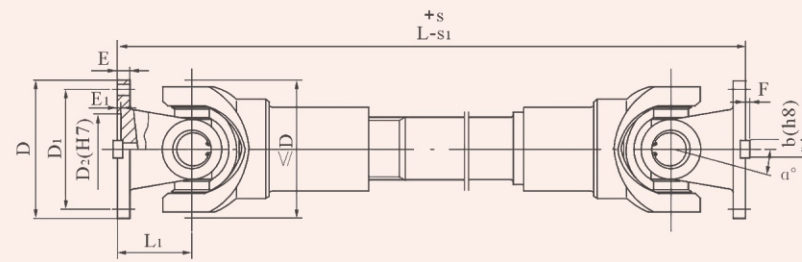

B型：可伸缩短型
B Style : Flexible short type

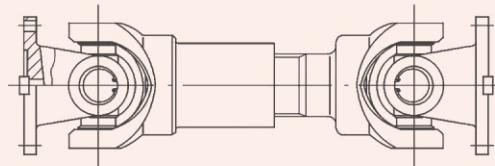

C型：无伸缩短型
C Style ; No-flexible short type

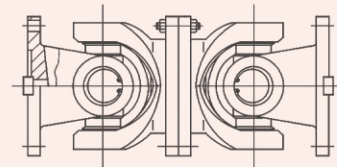

D型：无伸增长型
D Style : No-flexible long type

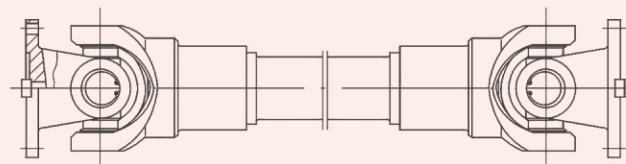

主要性能及尺寸 The main performance and sizes

型号 Style	Tm	Tp	Tf	A	α	L1	D	D1	D2	n-d	b	F	E	E1	S	S1
	kN · m				\leq	mm										
JXC110	1.1	0.93	0.71	0.48	15°	55	110	90	50	6- ϕ 9	15	5	12	4	20	15
JXC140	2.7	2.3	1.62	1.03		70	140	120	70	6- ϕ 11	16	5	13	4	20	15
JXC160	6	5.1	4	1.62		80	160	140	95	6- ϕ 13	20	6	14	4	25	20
JXC180	7	6	4.4	1.96		85	180	155	105	6- ϕ 15.5	24	7	15	4	25	20
JXC200	16	13.6	11	2.73		95	200	175	125	8- ϕ 15.5	28	8	16	5	30	25
JXC225	21	18	13.4	6.91		110	225	196	135	8- ϕ 17.5	32	9	18	5	35	25

注：1.Tm、Tp、Tf——分别为最大允许静转矩，允许脉动疲劳转矩及允许对称疲劳转矩。 2.A——反映轴承容量的值。

Note: 1.Tm, Tp, Tf - Represent the maximum allowed static torque, allowed pulse fatigue torque and allowed symmetric fatigue torque.
2.A-Represent the value of bearing capacity.

长度、重量及转动惯量 Length, weight and moment of inertia

型 式		JXC110	JXC140	JXC160	JXC180	JXC200	JXC225
F	Lmin mm	405	495	590	620	670	780
	Go kg	15.5	31	50	60	70	128
	G100 kg	1.68	2.38	3.21	3.21	4.17	6.45
	lo kgm ²	0.014	0.035	0.06	0.1	0.25	0.36
	I100 kgm ²	0.0008	0.001	0.004	0.007	0.013	0.016
B	Lmin mm	310	385	455	480	520	585
	Go kg	12	22	32	43	58	93
	lo kgm ²	0.01	0.025	0.042	0.07	0.18	0.25
C	Lmin mm	220	280	320	340	380	440
	Go kg	8	15	27	30	44	69
	lo kgm ²	0.008	0.02	0.033	0.055	0.14	0.2
D	Lmin mm	380	470	550	570	640	740
	Go kg	13	23	39	42	61	123
	G100 kg	1.68	2.38	3.21	3.21	4.17	6.45
	lo kgm ²	0.012	0.03	0.05	0.085	0.21	0.31
	I100 kgm ²	0.0008	0.001	0.004	0.007	0.013	0.016

注：1.Lmin——公称最短长度。 2.Go、lo——分别为最短长度Lmin时的自重及转动惯量。
3.G100、I100——分别为长度增加100mm时重量、转动惯量的增量。

Note: 1..Lmin - Nominal shortest length. 2.Go, lo - Represent weight and moment of inertia during the shortest length.
3.G100, I100 - Represent incremental weight and moment of inertia when the length is added by 100mm.



攀成钢无缝钢管机组
Pangang Group Chengdu Steel & Vanadium Co.,Ltd.Seamless Steel Pipe Unit

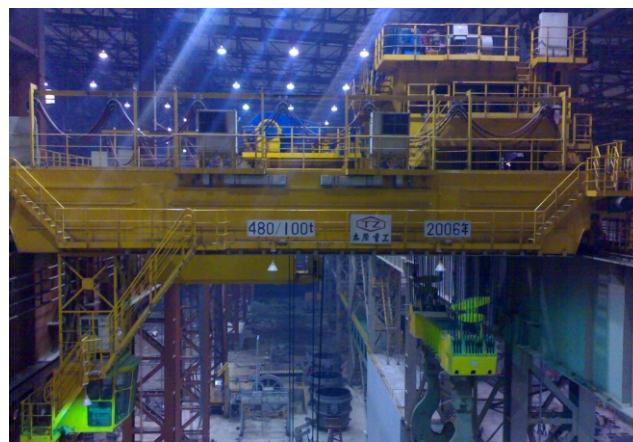

480/100t 铸造起重机
480/100t Ladle Crane



450t 铸造起重机
450t Ladle Crane

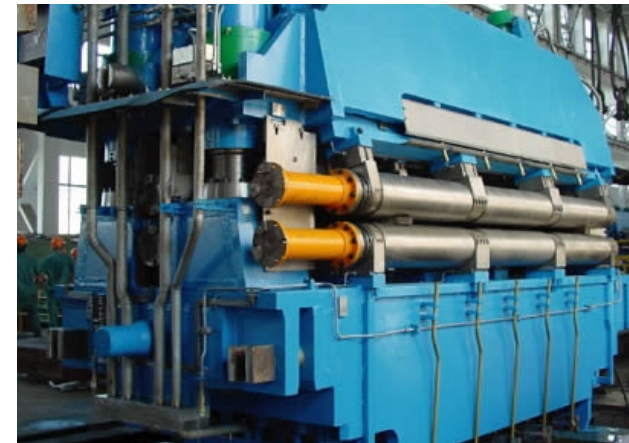

板坯连铸驱动部分
Slab Continuous Casting Machine Drive Part



480t钢包车驱动
480t Buggy Ladle Drive



轧钢机驱动
Rolling Mill Drive



薄板轧机驱动
Sheet Rolling Mill Drive



矫直机主驱动
Straightening Machine Masterdrive



步进加热炉驱动
Step Heating Furnace Drive

部份客户列表 List of Some Customers

海南航天工程	发射装置	Hainan Aerospace Engineering	Launcher
酒泉航天工程	发射装置	Jiuquan Aerospace Engineering	Launcher
攀成钢无缝	720 穿孔机组	Pancheng Steel Tube	720# Perforation Unit
西姆莱特钢管	250 穿孔机组	Ximulaite Steel	250# Perforation Unit
磐石钢管	100 穿孔机组	Panshi Gangguan	100# Perforation Unit
衡阳钢管	108 穿孔机组	Hengyang Gangguan	108# Perforation Unit
江阴兴澄钢铁	棒材轧机	Xincheng Steel	Bar Material Rolling Mill
华菱涟源钢铁	热轧板厂	VALIN LYTEEL	Hot Rolling Mill
南京钢铁股份	棒材分厂	Nanjing Steel Group	Bar Plant
首钢总公司	棒材厂	Shougang Corporation	Bar Plant
河北邯鄹钢铁	2120 板坯连铸机	Hebei Handan Steel	2120# Slab Continuous Casting Machine
首钢京唐	1650 板坯连铸机	Shougang Jingtang	1650# Slab Continuous Casting Machine
天铁集团	1650 板坯连铸机	Tiantie Group	1650# Slab Continuous Casting Machine
吉林钢铁	1300 板坯连铸机	Jilin Steel	1300# Slab Continuous Casting Machine
首钢京唐	480t 钢包车	Shougang Jingtang	480t Ladle Crane
马钢股份	480t 钢包车	Magang	480t Ladle Crane
河北宣钢	400t 钢包车	Hebei Xuangang	400t Ladle Crane
宝钢股份	350t 钢包车	Baosteel	350t Ladle Crane
太钢股份	350t 钢包车	Taiyuan Iron & Steel Co., Ltd	350t Ladle Crane
天铁集团	320t 钢包车	Tiantie Group	320t ladle Crane
大连重工	450t 钢包车	Dalian Heavy Industry	450t Ladle Crane
无锡巨力	480t 钢包车	Juli Heavy Industry	480t Ladle Crane
秦冶重工	350t 钢包车	Qinye Heavy Industry	350t Ladle Crane
东方冶金车辆	300t 钢包车	Oriental metallurgy vehicle	300t Ladle Crane
宝钢股份	矫直机	Baosteel	Straightener
舞阳新钢铁	矫直机	Wuyang New Steel	Straightener
邯宝钢铁	矫直机	Hanbao Steel	Straightener

螺纹紧固件预紧力矩推荐值

Recommended value of preloaded torque of thread fasteners

螺纹规格 d×P Thread Specification	8.8级 8.8 class	10.9级 10.9 class	12.9级 12.9 class
M6	6	8	10
M8x1	14	20	25
M10x1	45	65	80
M12x1.5	80	110	130
M14x1.5	130	180	220
M16x1.5	195	275	330
M18x1.5	280	400	480
M20x1.5	400	570	680
M22x1.5	520	735	880
M24x2	650	920	1100
M27x2	940	1340	1600
M30x2	1350	1900	2280
M33x2	1700	2440	2930
M36x2	2200	3150	3800

N·m

注：螺栓的机械性能应符合GB/T5785的规定，螺母的机械性能应符合GB/T6176的规定。

Note: The mechanical capacity of bolts should be accorded with GB/T5785 and the mechanical capacity of nuts should be accorded with GB/T6176.

